

BRExhaust™

A **MAGNAFLOW GROUP** COMPANY

INSTALLATION INSTRUCTIONS | PART NO. 106-0630

BILL OF MATERIALS:

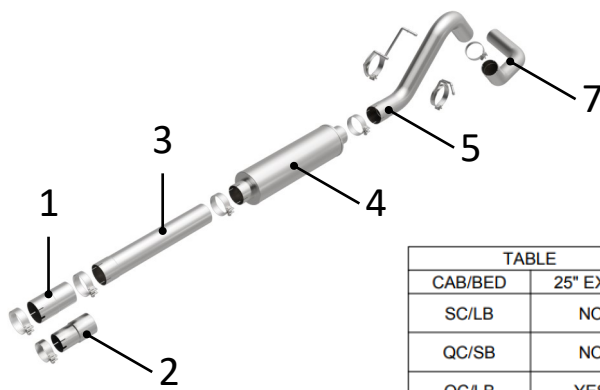

TABLE	
CAB/BED	25" EXTN
SC/LB	NO
QC/SB	NO
QC/LB	YES
MC/SB	YES

1. INLET ADAPTER. HO
2. INLET ADAPTER.
3. 25" EXTENSION PIPE
4. MUFFLER ASSEMBLY
5. OVER AXLE PIPE
6. TAIL PIPE

STEP 1:

(Carefully read all instructions before installation) Disconnect the vehicle's battery before removal of the OEM exhaust system. This will prevent electrical accidents and will reset the computer if it applies to the vehicle. Remove existing exhaust system from the vehicle. Only remove parts that will be replaced. Clean existing flange with a wire brush to ensure proper sealing.

STEP 2:

Working front to rear loosen or remove all OEM band clamps and disengage all welded hangers from the rubber insulators. Be sure to retain all mounting hardware as it will be needed to install your new BRE system.

STEP 3:

Install the corresponding Adapter Pipe pertaining to your vehicle and loosely fasten it to the catalytic converter outlet using the supplied clamp. Next, refer to the table to the left select the appropriate extension pipes for your vehicles configuration. If applicable loosely attach the Extension Pipe to the Adapter Pipe using the supplied clamp.

STEP 4:

Loosely attach the Muffler Assembly using the supplied clamps.

STEP 5:

Next, loosely slip the Hanger Clamp Assembly over the Over Axle Pipe. Loosely secure using the supplied clamps. Engage the welded hangers of the Hanger Clamp Assembly to the rubber insulators.

STEP 6:

Install the Tail Pipe Assembly in the same way. The Outlet may be trimmed as desired.

STEP 7:

Once a final position has been chosen for the new exhaust system, evenly tighten all clamps from front to rear using the torque specifications on page one of the instructions. Inspect all fasteners after 25-50 miles of operation and re-tighten if necessary

WARNING:

When working on, under, or around any vehicle exercise caution. Please allow the vehicle's exhaust system to cool before removal, as exhaust temperatures may cause severe burns. If working without a lift, always consult vehicle manual for correct lifting specifications. Always wear safety glasses and ensure a safe work area. Serious injury or death could occur if safety measures are not followed.



BRExhaust recommends professional installation for all products

Technical Support: 1-800-631-7271

BRExhaust — 1901 Corporate Ctr, Oceanside, CA 92056

www.brexhaust.com