

### 1998-2003 FORD RANGER - 6CYL 3.0/4.0L, SUPER CAB, 6FT. BED

**Warning:** When working on under or around any vehicle exercise caution. Please allow the vehicle's exhaust system to cool before removal, as exhaust system temperatures may cause severe burns. If working without a lift, always consult vehicle manual for correct lifting specifications. Always wear safety glasses and ensure safe work area. Serious injury or death could occur if safety measures are not followed.

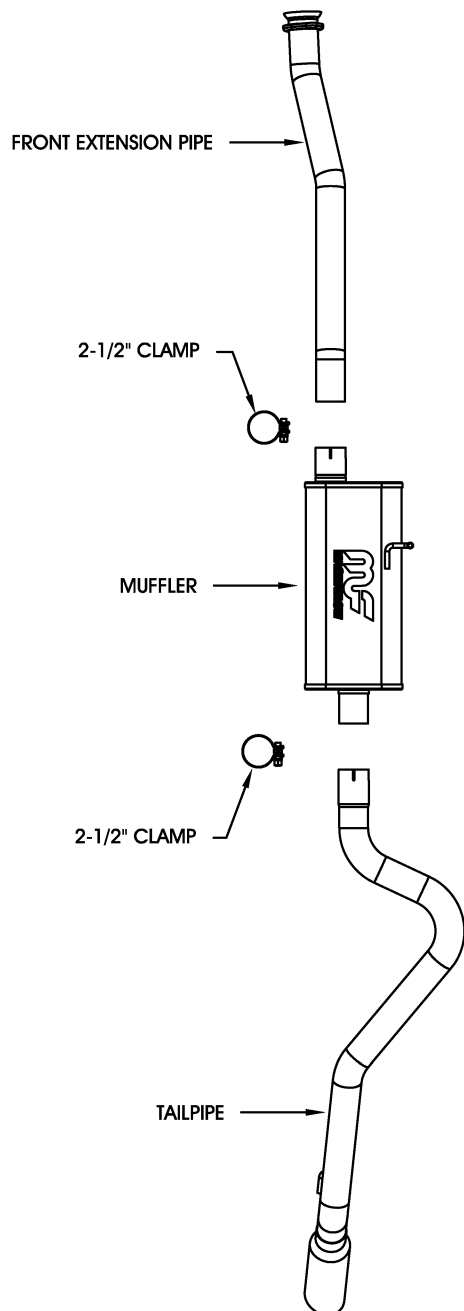

**Step 1:** (Carefully read all instructions before installation) To remove the OEM exhaust system, you will need to cut the tailpipe about 1" behind the muffler and extract it towards the rear of the vehicle. Unbolt the front extension pipe from the catalytic converter and remove it from the OEM rubber insulators (Do not discard the OEM fasteners, as they will be re-used to mount the new system.) Remove the muffler and tailpipe from the OEM rubber insulators. Do not damage the rubber insulators, as they will be re-used to mount the new system.

**Step 2:** Install the new front extension pipe by bolting it to the catalytic converter using the OEM fasteners. Leave all fasteners loose for final adjustment. Install the muffler by sliding the inlet end over the end of the front extension pipe and by fitting the welded hangers into the OEM rubber insulators. Install the tailpipe by sliding the outlet end of the muffler into the tailpipe, then fit the welded hangers into the OEM rubber insulators.

**Step 3:** With all components still loose, adjust the new system for overall aesthetics and clearance of frame & bodywork. (MAGNAFLOW recommends at least 1/2" of clearance between the exhaust tip and any body panels to avoid heat related bodywork damage or fire.)

**Step 4:** Once a final position has been chosen for the new system, evenly tighten all fasteners from front to rear. The supplied band clamps must be VERY tight to properly align the pipes and prevent leaks (Approximately 40 ft-lbs). Inspect all fasteners after 25-50 miles of operation and re-tighten if necessary.

Technical support: 1-800-959-9226 ext. 4500

\*MAGNAFLOW Performance Exhaust recommends professional installation on all their products