

2000-2001 FORD FOCUS - I-4 2.0L, HATCHBACK / SEDAN

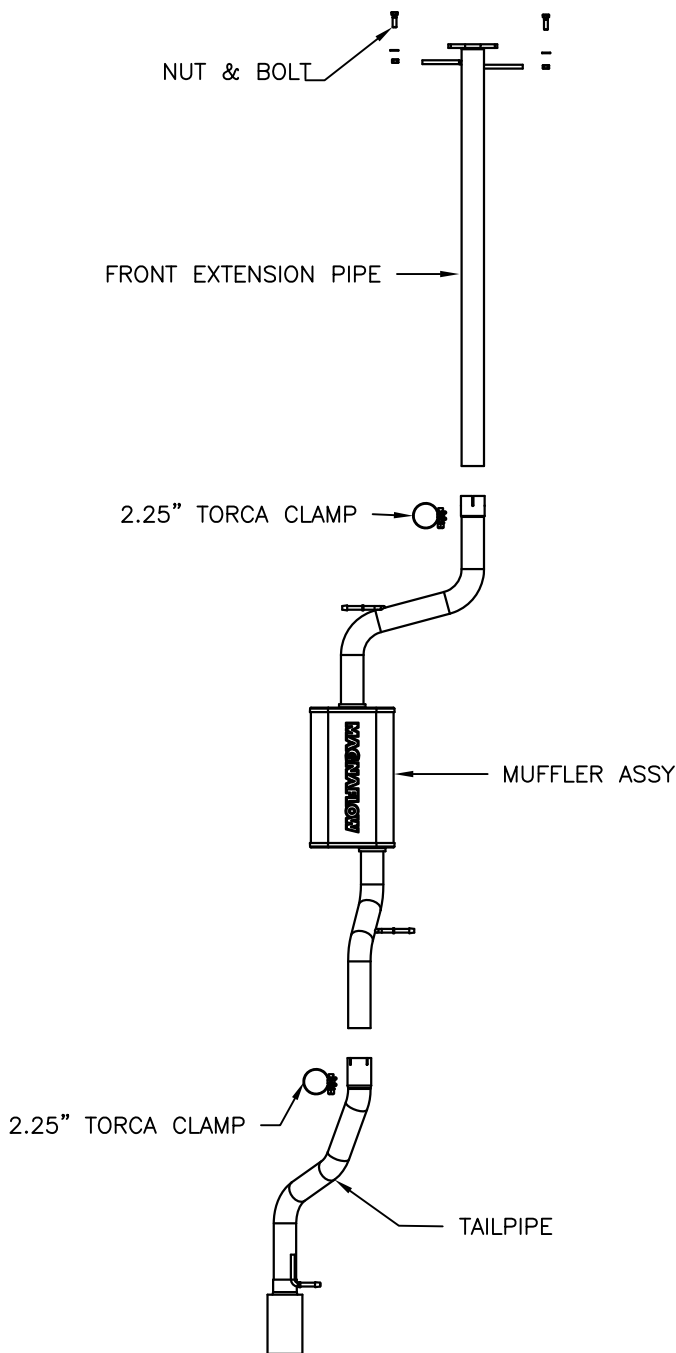

Warning: When working on under or around any vehicle exercise caution. Please allow the vehicle's exhaust system to cool before removal, as exhaust system temperatures may cause severe burns. If working without a lift, always consult vehicle manual for correct lifting specifications. Always wear safety glasses and ensure safe work area. Serious injury or death could occur if safety measures are not followed.

Step 1: (Carefully read all instructions before installation) To remove the OEM exhaust system, you will need to cut the pipe somewhere between the middle muffler and the rear control arm. Unbolt the front half of the system from the catalytic converter at the 2-bolt flange, and remove it from the OEM rubber insulators. Do not damage the OEM rubber insulators, nor discard the OEM fasteners, as they will be re-used to mount the new system. Remove the rear half of the system from the OEM rubber insulators, and extract it from the vehicle.

Step 2: Begin installation of the new system by bolting the new Front Extension Pipe to the catalytic converter using the provided Nuts and Bolts, and by fitting the welded hangers into the OEM rubber insulators. Leave all fasteners and clamps loose for final adjustment of the complete system. Install the new muffler by fitting the welded hangers into the OEM rubber insulators, and by fastening it to the Mid-Pipe using a supplied 2.25" Torca Clamp. Install the Tailpipe in the same fashion.

Step 3: With all components mounted loosely, adjust the system for overall aesthetics and clearance of frame & bodywork. (MAGNAFLOW recommends at least 1/2" of clearance between the exhaust system and any body panels to prevent heat-related body damage or fire.)

Step 4: Once a final position has been chosen for the new system, evenly tighten all fasteners from front to rear. The supplied Torca Clamps must be VERY tight to properly align the pipes, and prevent leaks (Approximately 40ft-lbs). Inspect all fasteners after 25-50 miles of operation and retighten if necessary.

*MAGNAFLOW Performance Exhaust recommends professional installation on all their products

Technical support: 1-800-959-9226 ext. 4500