

2007- VOLKSWAGEN RABBIT 2.5L

Warning: When working on, under, or around any vehicle exercise caution. Please allow the vehicle's exhaust system to cool before removal, as exhaust system temperatures may cause severe burns. If working without a lift, always consult vehicle manual for correct lifting specifications. Always wear safety glasses and ensure a safe work area. Serious injury or death could occur if safety measures are not followed.

Step 1: (Carefully read all instructions before installation) To Remove the OEM exhaust system, you will need to cut the pipe over the rear axle area. Disengage the welded hangers from the OEM rubber insulator and remove the rear section of the OEM exhaust system. Do not damage or discard the clamp or rubber insulators, as they will be reused to mount the new system. Loosen the OEM clamp and disengage the welded hanger from the rubber insulator and remove the rest of the OEM exhaust system.

Step 2: To install the new exhaust system, use a front to rear method. Install the Extension Pipe Assy first, then install the new Muffler Assembly by fitting the welded hangers into the rubber insulators, and by reusing the OEM clamp. Leave all clamps loose for the final adjustment of the complete system. Using a supplied a 2.25" clamp, install the rear tailpipe assembly in a similiar fashion.

Step 3: With all components mounted loosely, adjust the system for overall aesthetics and clearance of frame & bodywork. (MAGNAFLOW recommends at least 1/2" of clearance between the exhaust system and any body panels to prevent heat-related body damage or fire.)

Step 4: Once a final position has been chosen for the new system, evenly tighten all fasteners from front to rear. The supplied band clamps must be VERY tight to properly align the pipes and prevent leaks (Approximately 40ft-lbs). U-bolt clamps should be tightened to approximately 30-35ft-lbs. Inspect all fasteners after 25-50 miles of operation and retighten if necessary.

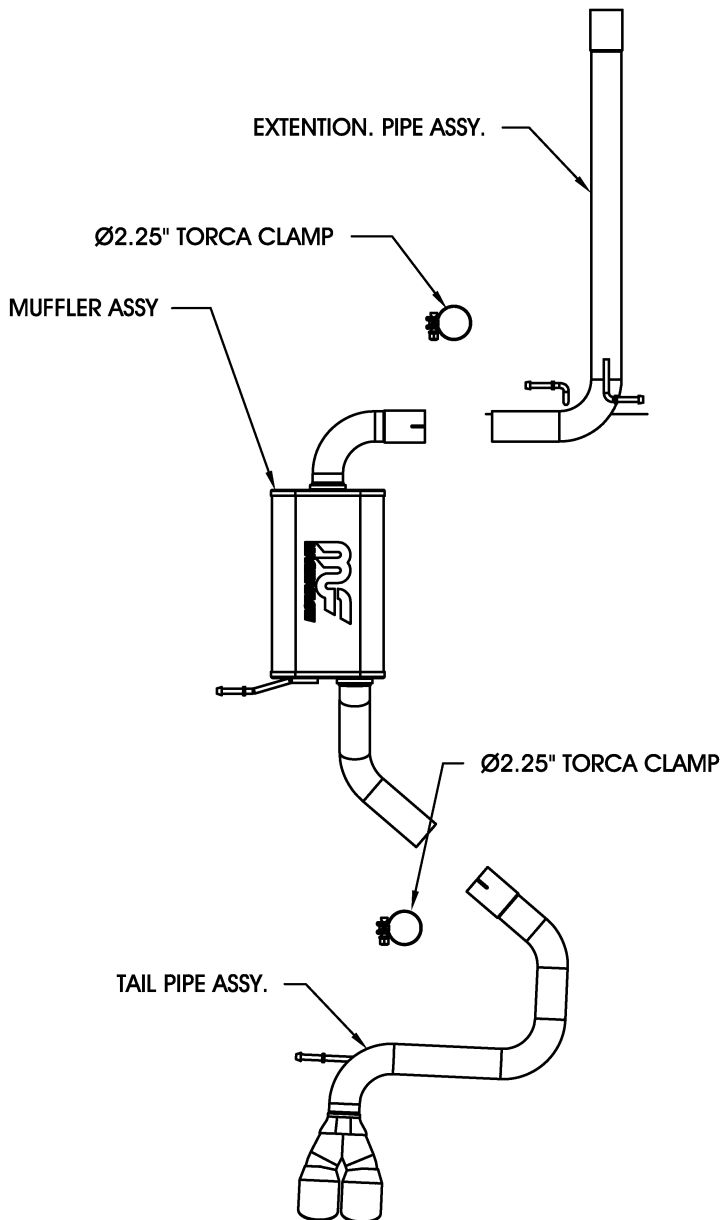

*MAGNAFLOW Performance Exhaust recommends professional installation on all their products

Technical support: 1-800-959-9226 ext. 4500