



INSTALLATION INSTRUCTIONS



2014-2015 CHEVROLET CAMARO 7.0L | PART NO. 19013

BILL OF MATERIALS:

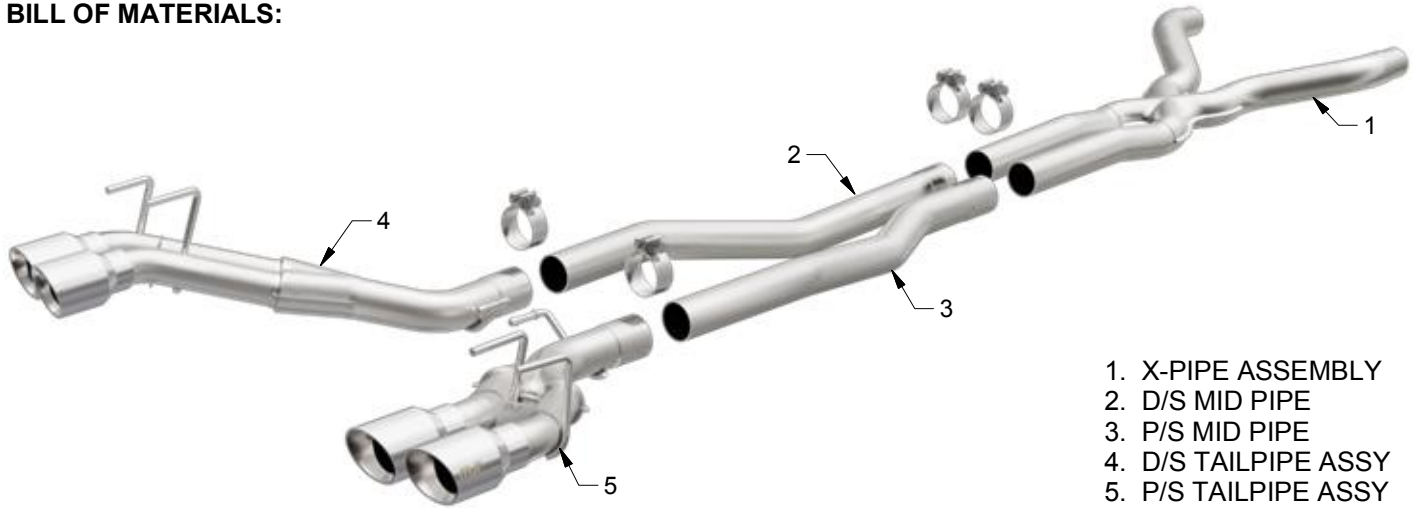

- 1. X-PIPE ASSEMBLY
- 2. D/S MID PIPE
- 3. P/S MID PIPE
- 4. D/S TAILPIPE ASSY
- 5. P/S TAILPIPE ASSY



WEAR SAFETY GLASSES



READ INSTRUCTIONS THOROUGHLY BEFORE INSTALLING PRODUCT

SHOP SUPPLIES:



SPRAY LUBRICANT

To ease removal of existing exhaust components (especially on older vehicles) spray penetrating lubricant on all fasteners and hangers/insulators that will be loosened or removed and let soak before disassembly.

HARDWARE KIT:

- 1. [4] 3.00" Clamps

MINIMUM REQUIRED TOOLS:



15mm, 13mm,



Hanger Tool (Or Pry Bar)

MAGNAFLOW RECOMMENDS PROFESSIONAL INSTALLATION ON ALL THEIR PRODUCTS



WARNING: When working on, under, or around any vehicle exercise caution. Please allow the vehicle's exhaust system to cool before removal, as exhaust system temperatures may cause severe burns. If working without a lift always consult vehicle manual for correct lifting specifications. Always wear safety glasses and ensure a safe work area. Serious injury or death could occur if safety measures are not followed.

ATTENTION: Always install any supplied band or U-bolt clamps to the proper torque specifications of 40-45 ft-lbs for band clamps and 30-35 ft-lbs for U-bolt clamps. Over tightening will result in the clamp breaking and will NOT be warranted by MagnaFlow.

INSTALLATION INSTRUCTIONS



Step 1. To remove the OEM exhaust system you will first need to loosen the clamps attaching it to the catalytic converter outlet pipes, then working front to rear (with the exhaust supported) disengage all welded hangers from the rubber insulators. The OEM exhaust system can now be removed. Retain all mounting hardware as it will be needed to install your new MAGNAFLOW system.



Step 2. Begin installing the new system by loosely attaching the inlets of the X-Pipe Assembly to the catalytic converter outlets using the OEM clamps.

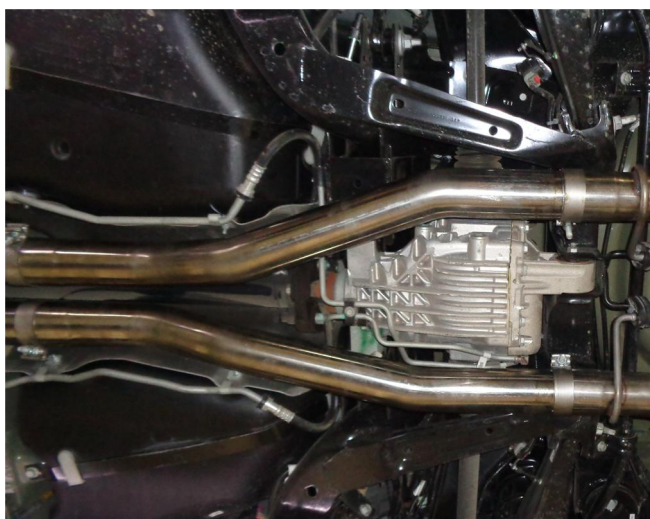

Step 3. Next, loosely install both driver and passenger side Mid Pipes to the X-Pipe Assembly using the supplied clamps.

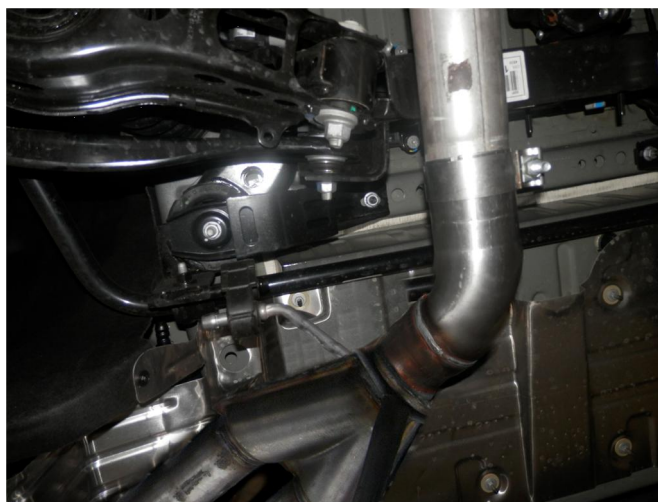

Step 4. Loosely install both Tailpipe Assemblies using the supplied clamps. Locate all welded hangers to the OEM rubber insulators.



Step 5. Once a final position has been chosen for the new exhaust system, evenly tighten all clamps from front to rear using the torque specifications on page one of the instructions. Inspect all fasteners after 25-50 miles of operation and re-tighten if necessary.